

Semiconductor Plant Gas Detector

XPS-7

Instruction Manual

- Store this Instruction manual in a convenient location, and consult it whenever necessary.
- Operate the product only after reading and fully understanding the content of this manual.



NEW COSMOS ELECTRIC CO., LTD.

Instruction manual No.

XPS-7T(11)

TABLE OF CONTENTS



1	Introduction	1
2	Contents of This Package	2
3	Sensor Units	2
4	Component Names and Functions	3
5	Operating Procedure	6
5-1	Inserting Batteries	6
5-2	Installing the Sensor Unit	7
5-3	Turning the Gas Detector ON	8
5-4	Detection	8
5-5	Ending Detection.....	8
6	Logger Function	9
7	Replacing the Filter	10
8	Daily and Periodic Inspections	11
9	Troubleshooting	11
10	Consumable Parts and Options	11
11	Warranty	12
12	Specifications	13

1 Introduction





- Thank you for purchasing the XPS-7 Semiconductor Plant Gas Detector. To ensure correct operation, please read this operation manual carefully.
- This product is designed to detect gas leaks in semiconductor manufacturing plants. Sensor units (purchased separately) can be switched to detect a variety of gases.
- Read and be sure you fully understand this manual even if you have used a Gas Detector before.
- Do not use the Gas Detector for any purpose other than that for which it was intended. Do not attempt to use the product in a way other than that described in this manual.

● Explanation of Symbols

This manual uses the following symbols. Their meanings must be understood and observed to ensure safe operation of the Gas Detector.

 DANGER	Indicates an impending hazardous situation that, if not avoided, could result in serious injury or death.
 WARNING	Indicates a potentially hazardous situation that, if not avoided, could result in serious injury or death.
 CAUTION	Indicates a potentially hazardous situation that, if not avoided, could result in minor injury or physical damage.
Note	Indicates operational advice and/or instructions.

- Observe the following precautions to ensure safe operation of the Detector.

 WARNING :	The Gas Detector is not explosion-proof and must be used in a non-hazardous location.
 CAUTION :	The Gas Detector is not drip-proof and must be used in a location free from splashing water.
 CAUTION :	Do not allow the Gas Detector to be subjected to mechanical shock by being dropped or struck.
 CAUTION :	The Gas Detector must be turned ON in a clean-air environment. Otherwise, the performance of the Detector may be impaired and normal detection may not be possible.
 CAUTION :	The shelf life of the sensor unit is six months. Always check the sensor unit to be sure its life has not expired prior to use. Normal detection may not be possible if an expired sensor unit is installed.

- Observe the following precautions for the storage environment and method of storing the Gas Detector.

 **WARNING :** Do not store the Gas Detector for long periods in locations with high temperatures or high humidity. Otherwise, the performance of the Detector may be impaired.

 **CAUTION :** Do not subject the Gas Detector to sudden changes in temperature or humidity. Otherwise, the performance of the Detector may be impaired.

 **CAUTION :** If the Gas Detector is not to be used for a long time, remove the batteries before storing it.

2 Contents of This Package

- The following components are included with the Gas Detector. Ensure that all components are present before attempting to use the Detector.

<input type="checkbox"/> Gas Detector	1	<input type="checkbox"/> Filters	2
<input type="checkbox"/> Shoulder strap	1	<input type="checkbox"/> AA alkaline batteries.....	4
<input type="checkbox"/> Gas inlet tube.....	1	<input type="checkbox"/> Inspection results.....	1
<input type="checkbox"/> Instruction manual.....	1		

3 Sensor Units

Model	Detected gases		FS	Alarm setting	
				1st level	2nd level
XDS-7NH	NH ₃	Ammonia	100 ppm	12 ppm	25 ppm
XDS-7SH	SiH ₄	Silane	25 ppm	2.5 ppm	5 ppm
XDS-7DC	SiH ₂ Cl ₂	Dichlorosilane	25 ppm	2.5 ppm	5 ppm
XDS-7AH	AsH ₃	Arsine	250 ppb	25 ppb	50 ppb
XDS-7PH	PH ₃	Phosphine	1 ppm	0.15 ppm	0.3 ppm
XDS-7BH	B ₂ H ₆	Diborane	500 ppb	50 ppb	100 ppb
XDS-7SE	H ₂ Se	Hydrogen selenide	250 ppb	25 ppb	50 ppb
XDS7GH	GeH ₄	Germane	1 ppm	0.1 ppm	0.2 ppm
XDS-7CL	Cl ₂	Chlorine	5 ppm	0.25 ppm	0.5 ppm
XDS-7CF	ClF ₃	Chlorine trifluoride	1 ppm	0.05 ppm	0.1 ppm
XDS-7HC	HCl	Hydrogen chloride	25 ppm	2.5 ppm	5 ppm
XDS-7HF	HF	Hydrogen fluoride	10 ppm	1.5 ppm	3 ppm
XDS-7HB	HBr	Hydrogen bromide	10 ppm	1.5 ppm	3 ppm
XDS-7NO	NO	Nitrogen monoxide	100 ppm	12 ppm	25 ppm
XDS-7HS	H ₂ S	Hydrogen sulfide	50 ppm	5 ppm	10 ppm
XDS-7CO	CO	Carbon monoxide	250 ppm	12.5 ppm	25 ppm
XDS-7DS	Si ₂ H ₆	Disilane	25 ppm	2.5 ppm	5 ppm
XDS-7F2	F ₂	Fluorine	5 ppm	0.5 ppm	1 ppm
XDS-7OZ	O ₃	Ozone	1 ppm	0.05 ppm	0.1 ppm

Contact an authorized representative of New Cosmos regarding other detectable gases not listed in the table.

4 Component Names and Functions

Main Unit

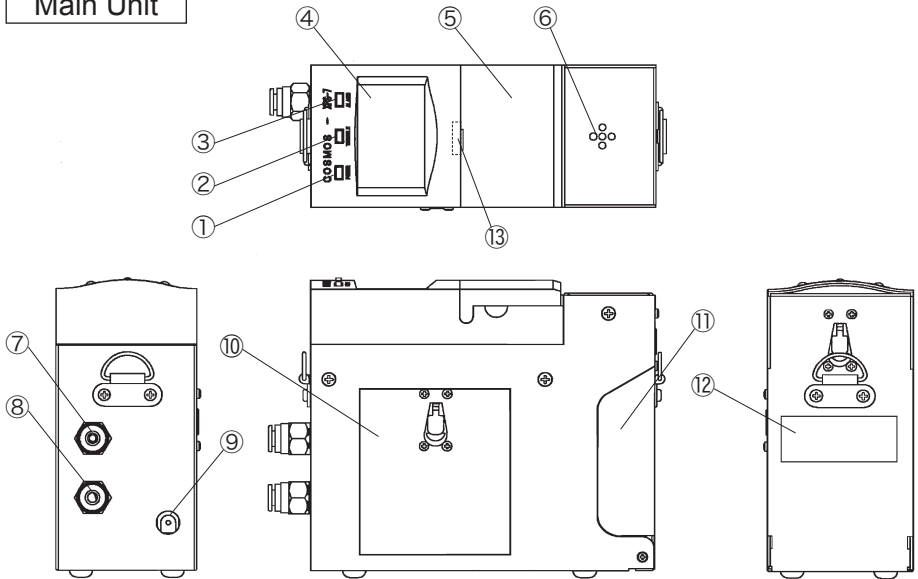

No	Name	Function
①	Power lamp (green)	Flashes during the warm up period after the power is turned ON and remains lit during operation.
②	Trouble lamp (yellow)	Flashes when an error occurs.
③	Alarm lamp (red)	Flashes when the detected gas concentration reaches the alarm point.
④	LCD display	Indicates gas concentration and other information.
⑤	Key switch cover	Lightly pull the cover toward you to open it and access the key switches.
⑥	Buzzer speaker	
⑦	Gas inlet	Sampled gas aspiration inlet. (6 dia.) Attaches to the gas inlet tube.
⑧	Gas outlet	Exhaust outlet for sampled gas (6 dia.)
⑨	Adapter connector	Connects to the 100-VAC/6-VDC adapter plug.
⑩	Battery cover	Lift the snap lock and open the cover to insert batteries.
⑪	Sensor cover	Lift the snap lock and open the cover to insert the sensor unit.
⑫	Sensor window	Used to check the sensor unit that is installed.
⑬	LED (red) (Battery check)	Lit if the key switch cover is open with the Gas Detector turned OFF, when batteries are inserted, or when batteries are low.

Key Switches

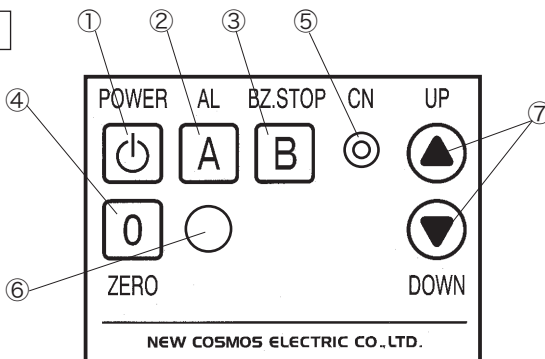

No	Name	Function
①	Power switch	Press and hold to turn the Gas Detector ON and OFF.
②	Alarm setting indicator switch	Used to check the alarm settings. Press the switch repeatedly to display the first level alarm setting, second level alarm setting, and gas concentration.
③	Buzzer stop switch	
④	Zero calibration switch	Press and hold to adjust the zero point automatically.
⑤	CN jack	Connects to the plug of a CA-7 Communications Adapter (option) used for log data collection.
⑥	Special command switch	Used with the logger function.
⑦	UP/DOWN switches	Used to set the start time and other logger function settings.

LCD Display

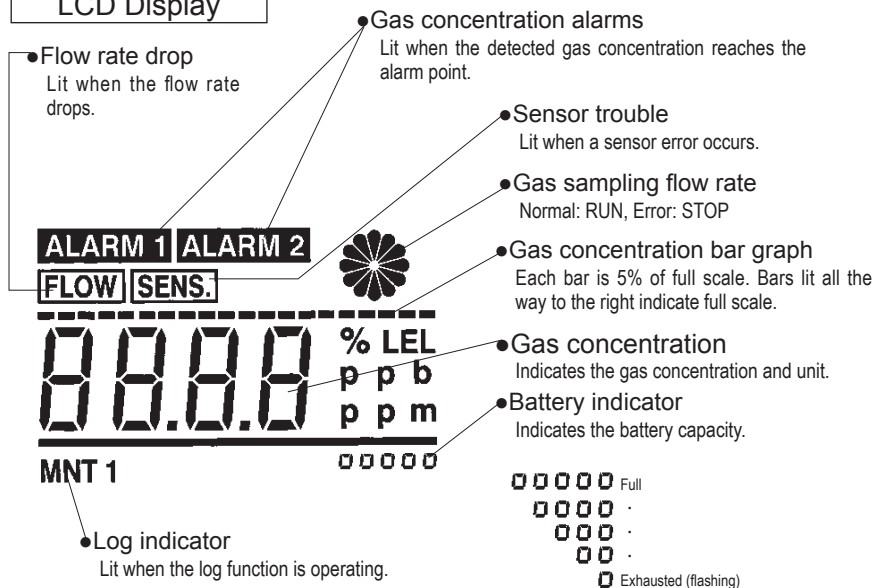

Gas Inlet Tube

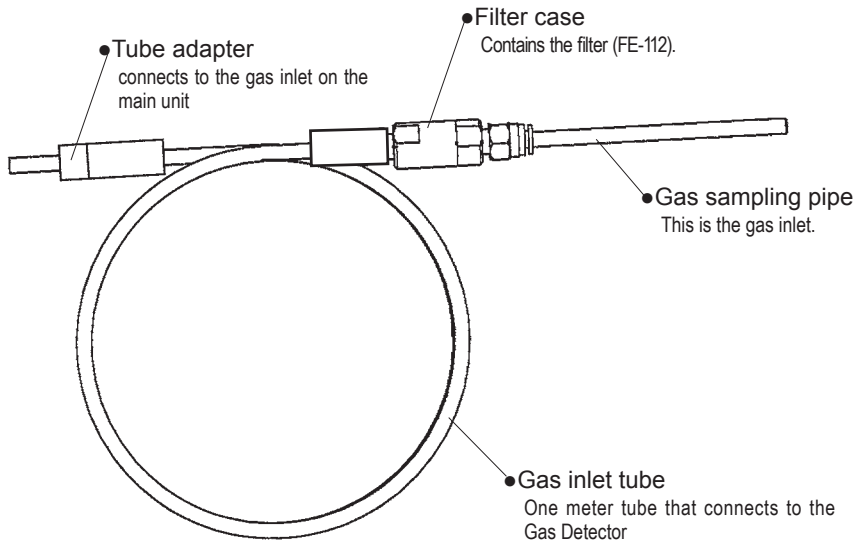

Note Attaching and Removing the Gas Inlet Tube

●Attaching

Insert the tube into the coupling on the Gas Detector inlet and secure it in place with the locking tab to seal the edge of the tube. After the tube is attached, make sure that it will not pull out.

●Removing

Press in the release ring on the coupling and simultaneously pull out the gas inlet tube.

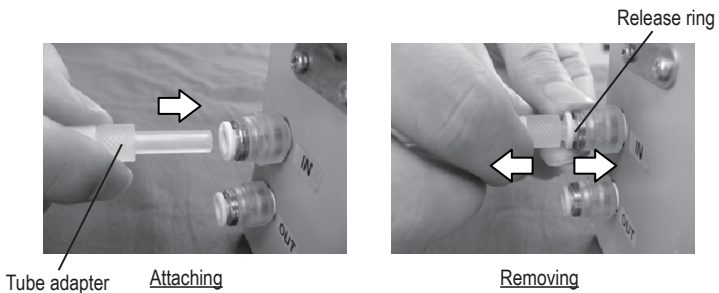

5 Operating Procedure

- Inspect the Gas Detector daily before using it. (Refer to page 13.) If the Detector is used without first performing the inspection, normal detection may not be possible and leaks may not be detected.

⚠ CAUTION: The Gas Detector must be turned ON in a clean-air environment. Otherwise, the performance of the Detector may be impaired and normal detection may not be possible.

5-1 Inserting Batteries

- ① Lift the snap lock on the battery cover and pull the cover toward you to open it.
- ② Insert the four AA alkaline batteries provided and make sure they are inserted according to the polarity indicated in the battery compartment.
- ③ Close the battery cover.

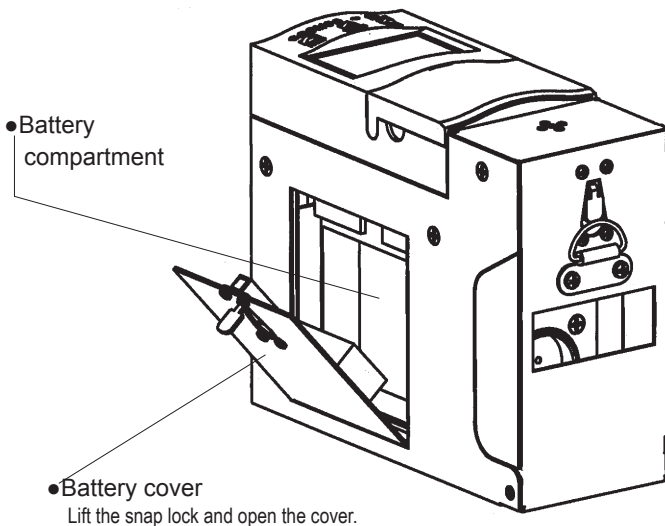

⚠ WARNING : Replace all four batteries at the same time with fresh, new batteries. Also make sure that the replacement batteries are all the same brand and type.

⚠ CAUTION : Always replace the batteries in the following situations.

- ① The battery indicator shows a flashing box (□) when the Gas Detector is ON. (Refer to LCD display on page 5.)
- ② Nothing operates when the Gas Detector is ON.
- ③ The battery check LED (red) is glowing very brightly (as bright as □ above) when the Gas Detector is OFF. (Refer to item □ on page 4.)

5-2 Installing the Sensor Unit

- ① Lift the snap lock on the sensor cover and pull the cover toward you to open it.
- ② Note the position of the connector and the mounting slot as you push the sensor unit into place.
- ③ When the sensor unit is securely in place, close the sensor cover.

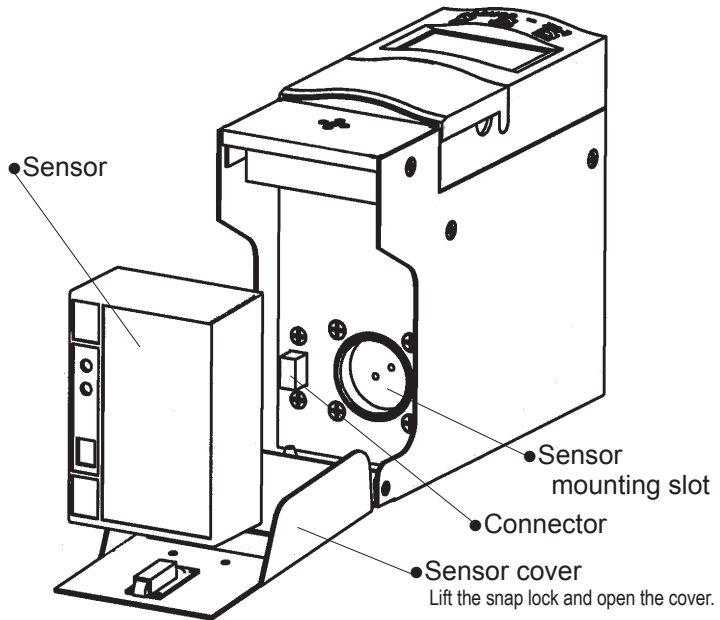

- ⚠ CAUTION :**
- If the Gas Detector is used without a properly seated sensor unit, the Gas Detector will not be air-tight and normal detection may not be possible. Make sure the unit is properly seated.
 - Use the sensor stocker model EC-7 (purchased separately) to supply power to the sensor unit. A sensor unit that does not have power to it cannot detect gases and may cause the sensor trouble indicator to light. A sensor unit installed in the Gas Detector is powered even if the Gas Detector is turned OFF, as long as the batteries are charged.
 - When a sensor unit is replaced (shipped from the plant), install it in the Gas Detector or connect it to the sensor stocker model EC-7 to supply a sufficient amount of power to the new unit before turning ON the Gas Detector and using it for the first time.
 - This Gas Detector uses XDS-7 sensor units and is not compatible with CDS-7, COS-7, CHS-7 or any other sensor units.

5-3 Turning the Gas Detector ON

- ① Press and hold the power switch. The buzzer sounds, the green power lamp flashes, and self-diagnosis begins. The diagnostic procedure lasts about 30 seconds.
- ② When self-diagnosis is completed, zero adjustment is performed automatically, the green power lamp lights, and the unit is ready to detect gas.

 **CAUTION :** • The Gas Detector must be turned ON in a clean-air environment. Do not allow the Detector to draw in gas while it is warming up. Otherwise, zero adjustment will not be performed properly and normal detection will not be possible.
• Wait at least 1 s before turning the Gas Detector back ON after a power failure.

5-4 Detection

Place the gas sampling pipe near the target detection area. When the unit detects gas, the concentration of the detected gas is displayed. If the detected gas concentration level reaches the alarm point, the alarm lamp lights and the buzzer sounds as shown in the table below.

Gas concentration exceeds	Red ALARM LED	Audio alarm
1 st stage alarm set value	Flashes	No sound
2 nd stage alarm set value	Flashes fast	Beeps fast
F. S. value	Flashes faster	Steady tone

 **CAUTION :** Do not allow water or other liquids to enter the Gas Detector. Any liquid will cause the Gas Detector to fail.

5-5 Ending Detection

When detection is completed, place the Gas Detector in a clean-air environment and allow it to draw in clean air until the concentration indicator reads zero. Press and hold the power switch until the Detector turns OFF.

 **CAUTION :** After an adsorbent gas has been detected, replace the filter with a new one before attempting to detect another gas. Normal detection is not possible with a contaminated filter.

6 Logger Function

The Gas Detector can record up to 22 hours of detection data. The recorded data can be written to a personal computer using optional components that can be purchased separately. (See 10. *Consumable Parts and Options.*)

Note

- Maximum gas concentration is recorded every 10 s after logging begins.
- New log data is stored in the Gas Detector by overwriting old data.
- The logger function terminates when the Gas Detector is turned OFF.
- Date settings are not supported.
- Refer to the *XPS-7 Log Data Download Software* in the XPS-7L Instruction Manual for the procedure used to write log data to a personal computer.

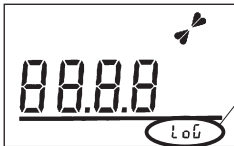

① Press the DOWN switch (▼) once in RUN mode.

LOG will be displayed on the lower right corner of the LCD display and the log start time can be entered.

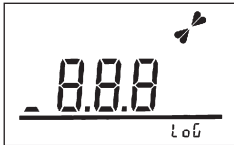

② Press the SPECIAL COMMAND switch and the digit that will change starts to flash. Use the UP/DOWN and SPECIAL COMMAND switches to set the log start time.



Example: Enter the numbers shown in the display on the right to set the log start time at 1:20 pm.



③ After the time has been set, press and hold the ZERO switch. MNT1 (maintenance mode 1) will be displayed on the lower left corner of the LCD display and log recording will begin.



④ To end log recording, press the BUZZER STOP switch while LOG is displayed on the lower right corner of the LCD display. MNT1 will no longer be displayed and log recording will stop.

Note

- Pressing the UP (▲) or DOWN (▼) switch repeatedly in RUN mode changes the display on the bottom right corner of the LCD display as shown below. These are factory adjustments that are not available for user application

25	0	CG	40	F	PH3	Pr	80	P	200
----	---	----	----	---	-----	----	----	---	-----

7 Replacing the Filter

- ① Twist the filter holder with detection probe to open it.
- ② Use a pair of tweezers to remove the O ring and filter.
- ③ Insert a new filter and the O ring.
- ④ Reassemble the filter case.

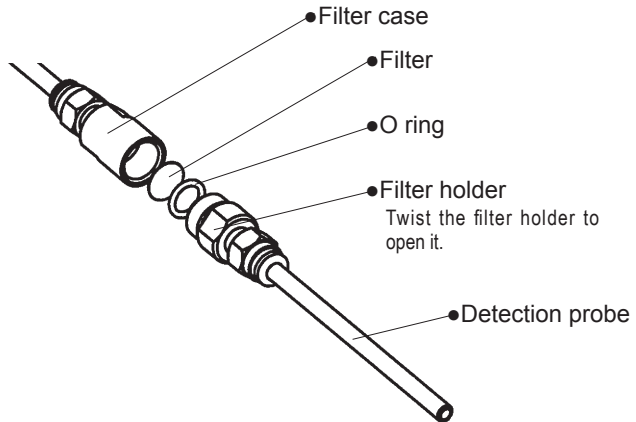

8 Daily and Periodic Inspections

Daily Inspections

- Checking the Gas Inlet Tube
Is the tube damaged? If so, replace it with a new one.
- Checking the Filter
If the filter is dirty and discolored, replace it with a new one.

Periodic Inspections

- To maintain accuracy, it is recommended that the Gas Detector be given periodic inspections and adjustments at least once a year by an authorized representative of New Cosmos.
- Replace the sensor unit every six months.

Note Clean the Gas Detector by gently wiping it with a cloth dampened with water.

9 Troubleshooting

Symptom	Possible cause	Corrective action	Reference
The power does not come ON even when the power switch is pressed and held.	Battery polarity is reversed.	Correct the battery polarity.	Page 6
	The batteries are low.	Replace the batteries.	
	The sensor unit is not installed.	Install a sensor unit.	Page 7
Abnormal drop in the flow rate	The filter is clogged.	Replace the filter with a new one.	Page 10
Sensor error	There is not enough power to the sensor unit.	Make sure the sensor unit has sufficient power when installing it.	Page 7
	The shelf life of the sensor unit has expired.	Replace the sensor unit with a new one.	Page 7

10 Consumable Parts and Options

Part name	Model number	Remarks
Sensor unit	XDS-7 □	Contact an authorized representative of New Cosmos regarding gases that can be detected.
Filters (10 per set)	FE-112	
AC adapter *		Special adapter for 100-240V AC/6V DC.
Sensor Stocker	EC-7	Provides power for up to six sensor units at one time.
Log data download software *	XPS7L	Required to write log data to a personal computer.
Communications adapter *	CA-7	
Serial crossover cable *	KRS-L09-2K	

* Not available for the XPS-7 with CE marking.

11 Warranty

New Cosmos Electric Company Limited (New Cosmos) offers the following as the sole and exclusive limited warranty available to Customer.

This warranty is in lieu of, and customer waives, all other warranties of any kind or nature, expressed or implied, including without limitation, any warranty for merchantability or fitness for a particular purpose. The remedies set forth herein are exclusive.

New Cosmos warrants to the original purchaser and no other person or entity (customer) that gas detection product supplied by New Cosmos shall be free from defects in materials and workmanship for a period of one (1) year from the date of purchase. This warranty does not include consumables, such as fuses, filters, etc. Certain other accessories not specifically listed here may have different warranty periods.

After examination of allegedly defective product return to New Cosmos, with freight prepaid, should the product fail to conform to this warranty, customer's only remedy and New Cosmos's only obligation shall be, at New Cosmos's sole option, replacement or repair of such non-conforming product or refund of the original purchase price of the non-conforming product. In no event will New Cosmos be liable for any other special, incidental or consequential damages or losses of any kind whatsoever, including but not limited to, loss of anticipated profits and any other loss caused by reason of non-operation of the product.

This warranty is valid only if the product is maintained and used in accordance with New Cosmos's instructions and for recommendations. New Cosmos shall be released from all obligations under this warranty in the event repairs or modifications are made by persons other than its own or authorized service personnel or if the warranty claim results from physical abuse or misuse of the product.

12 Specifications

Detected gases	Gases found in semiconductor manufacturing plants
Detection principle	Electrochemical
Gas sampling method	Extractive
Detection range	As per specifications
Concentration display method	LCD display
Detection accuracy (See note 1.)	±10% of full scale
Response time (See note 1.)	Within 60 s (60% response)
Power supply	Four AA alkaline batteries or AC adapter (optional item)
Battery operating time (See note 2.)	Up to 12 hours of continuous operation (at 20°C with alkaline batteries and no alarms)
Operating temperature range	0 to 40°C
Dimensions	W 62 x H 150 x D 128 mm (projected portions excluded)
Mass	Approx. 1.3 kg
Approval (See note 3.)	CE (EMC Directive, 2014/30/EU)

Note 1: The detection accuracy and response time were measured under identical detection conditions.

Note 2: The operating time of the batteries depends on factors such as environmental conditions, operating conditions, the storage time, and the manufacturer.

Note 3: AC Adapter and Data Logger Software (optional items) are exempt from CE marking. (see on page 11)

Distributor:

Manufacturer:

New Cosmos Electric Co., Ltd.
2-5-4 Mitsuya-naka Yodogawa-ku
Osaka 532-0036, Japan
URL:<http://www.newcosmos-global.com>

